



TECHICAL DATA

Operating range: up to 4,2 m³/h with head up to 22 m.

Pumped liquid: clean, free of solids or abrasive substances, non viscous, non aggressive, non crystallized, chemically neutral, with properties similar to water.

Liquid temperature range: from 0 °C to +100 °C.

Ambient temperature: from -10 °C to +55 °C.

Humidity: ≤ 95%.

Motor protection: IP 44.

Insulation class: F.

Standard voltage: single phase ~220 V / 50 Hz.

Maximum operating pressure: 4 bar (liquid temperature 35° C), 2 bar (liquid temperature 65° C).

Minimum automatic (flow switch) operating pressure: 0,5 mwc.

Minimum automatic (flow switch) operating flow rate: = 2,5 l/min.

APPLICATIONS

The K-HA single impeller centrifugal pump is designed for boosting water pressures in houses and apartments (domestic properties), in order to provide additional pressure to hot and cold water taps and similar outlet points. The K-HA centrifugal pump is mainly intended for use in open vented systems(tanks), but may also be installed directly on the incoming water mains supply feeding a boiler, subject to the approval of the local Water Authority. The pump incorporates a flow switch that starts and stops the pump in line with the flow, when a tap is opened or closed. The pump is supplied with a 0,3 meter power cable.

CONSTRUCTION FEATURES OF THE PUMP

- Cast iron pump body and motor support with cataphoresis paint coating.
- Brass flow switch body.
- Technopolymer impeller.
- Carbon / ceramic mechanical seal.

PLUS

- Brass flow switch directly assembled on the delivery port of the pump body, and adjustable to 4 positions (45° from vertical)
- Automatic (using the flow switch), or manual operating modes
- Easy fixing bracket
- Rubber foot for better pump stability
- Possibility of operation without flow switch (with optional adaptor)
- Silent operation

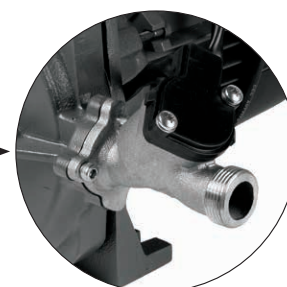

CONSTRUCTION FEATURES OF THE MOTOR

External ventilation cooling closed induction motor.

Rotor mounted on oversized greased permanently sealed ball bearings, to ensure silent operation and long life.

Built-in thermal and current overload protection, and a permanently connected capacitor.

Motor construction in accordance with CEI 2-3 - CEI 61-69 (EN 60335-2-41) standards.

MATERIALS

N.	PARTS *	MATERIALS
1	PUMP BODY	CAST IRON WITH CATAPHORESIS COATING
3	SUPPORT	CAST IRON WITH CATAPHORESIS COATING
4	IMPELLER	TECHNOPOLYMER B
7	SHAFT	STAINLESS STEEL AISI 416 X12CrS13 UNI 6900/71
16	MACHANICAL SEAL	CARBON/CERAMIC/HNBR
28	O-RING	NBR RUBBER

* In contact with liquid.

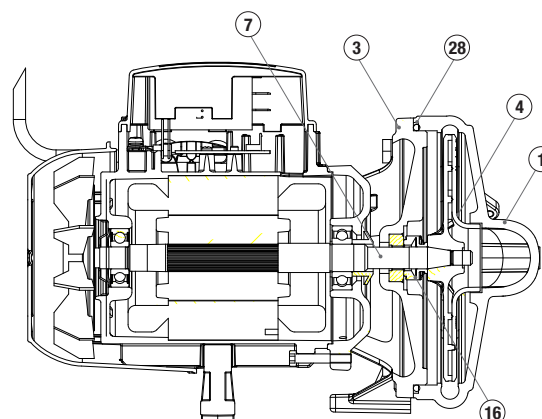

K-HA - CENTRIFUGAL PRESSURE BOOSTING PUMPS FOR WATER PRESSURE BOOSTING IN HOUSEHOLDS

Liquid temperature range: from 0 °C to +100 °C - Maximum ambient temperature: from -10 °C to +55 °C

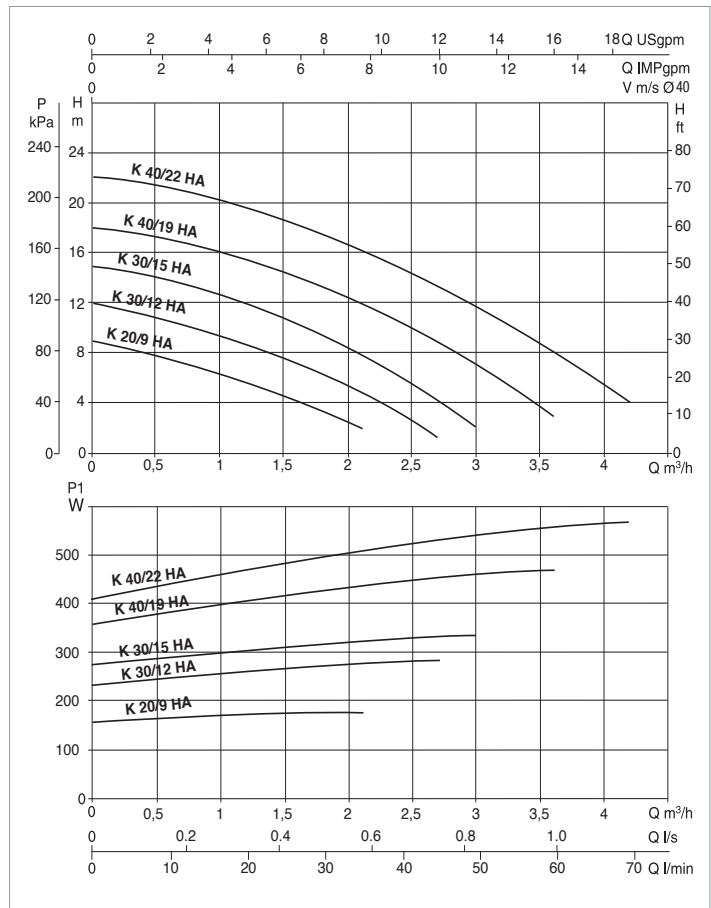
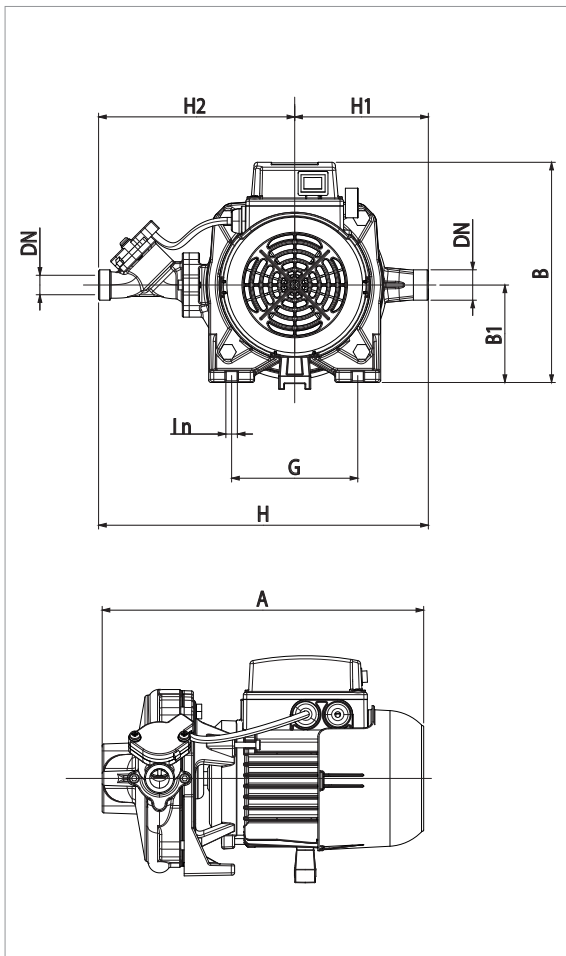

The performance curves are based on kinematic viscosity values = 1 mm²/s and density equal to 1000 kg/m³. Curve tolerance according to ISO 9906.

MODEL	Q=m ³ /h	0	0,5	1	1,5	2	2,5	3	3,5	4
	Q=l/min	0	8,3	16,6	25	33,3	41,6	50	58,3	66,6
K 20/9 HA	H (m)	8,9	7,8	6,3	4,5	2,5				
K 30/12 HA		12	10,8	9,3	7,6	5,4	2,6			
K 30/15 HA		14,8	14,1	12,7	10,7	8,4	5,4			
K 40/19 HA		18	17,3	16,1	14,4	12,4	10	7	3,6	
K 40/22 HA		22	21,4	20,2	18,6	16,6	14,3	11,7	8,7	5,5

MODEL	VOLTAGE 50 Hz	P1 MAX kW	P2 NOMINAL		In A	I st. A	cos φ	CAPACITOR (μF)	HOSE DIAMETER (mm)	MAXIMUM FLOW RATE (m ³ /h)	MAXIMUM HEAD (m)
			KW	HP							
K 20/9 HA	220 V	0,18	0,03	0,12	0,82	2,89	0,926	8	ø 16 mm	2,10	9
K 30/12 HA	220 V	0,28	0,12	0,16	1,28	4,09	0,969	8	ø 16 mm	2,40	12
K 30/15 HA	220 V	0,34	0,18	0,25	1,5	4,09	0,98	8	ø 16 mm	3,00	15
K 40/19 HA	220 V	0,47	0,25	0,34	2,25	7,6	0,905	8	ø 16 mm	3,60	18
K 40/22 HA	220 V	0,57	0,37	0,5	2,54	7,6	0,932	8	ø 16 mm	4,20	22

MODEL	A	B	B1	DN	G	H	H1	H2	I Ø	WEIGHT (kg)
K 20/9 HA	253	172	65	G ¾"	70	231	83	148	8	5,4
K 30/12 HA	282	192	85	G ¾"	110	287,5	116,5	171	9,5	7,9
K 30/15 HA	282	192	85	G ¾"	110	287,5	116,5	171	9,5	7,9
K 40/19 HA	280,5	192	85	G ¾"	110	287,5	116,5	171	9,5	8,9
K 40/22 HA	280,5	192	85	G ¾"	110	287,5	116,5	171	9,5	8,9